



# GN

Thermoforming Equipment



# GN 800



# At the leading edge

GN Thermoforming Equipment has set the world standard for the plastics industry by developing a complete line of robust and dependable thermoforming machines. These machines are easy to use and ideally suited to produce high quality thermoformed plastic products from a variety of roll-fed thermoformable materials.

Continuous research and development are the cornerstones of GN's advanced technology. Our team of experienced engineers focuses on equipment design and continuous improvement based on customer feedback and industry trends.

GN ensures the productivity of its thermoforming machines with one of the industry's most comprehensive customer service programs. Our worldwide network of agents and qualified GN technicians are available to offer a reliable after sales service.

Leading plastic package manufacturers around the world have come to rely on GN Thermoformers to make their businesses more productive and profitable.

## GN 800

The GN800 is the newest addition to GN's line of equipment. This High Speed Form/Cut/Stack Thermoformer is the first GN model that offers movable top and bottom platens.

In partnership with an experienced Italian machine manufacturer, GN is re-introducing to the market a Form/Cut/Stack Thermoformer that was manufactured and distributed worldwide for many years. With the input of customers and toolmakers, the enhanced GN800 will continue to service the production requirements of companies around the world.

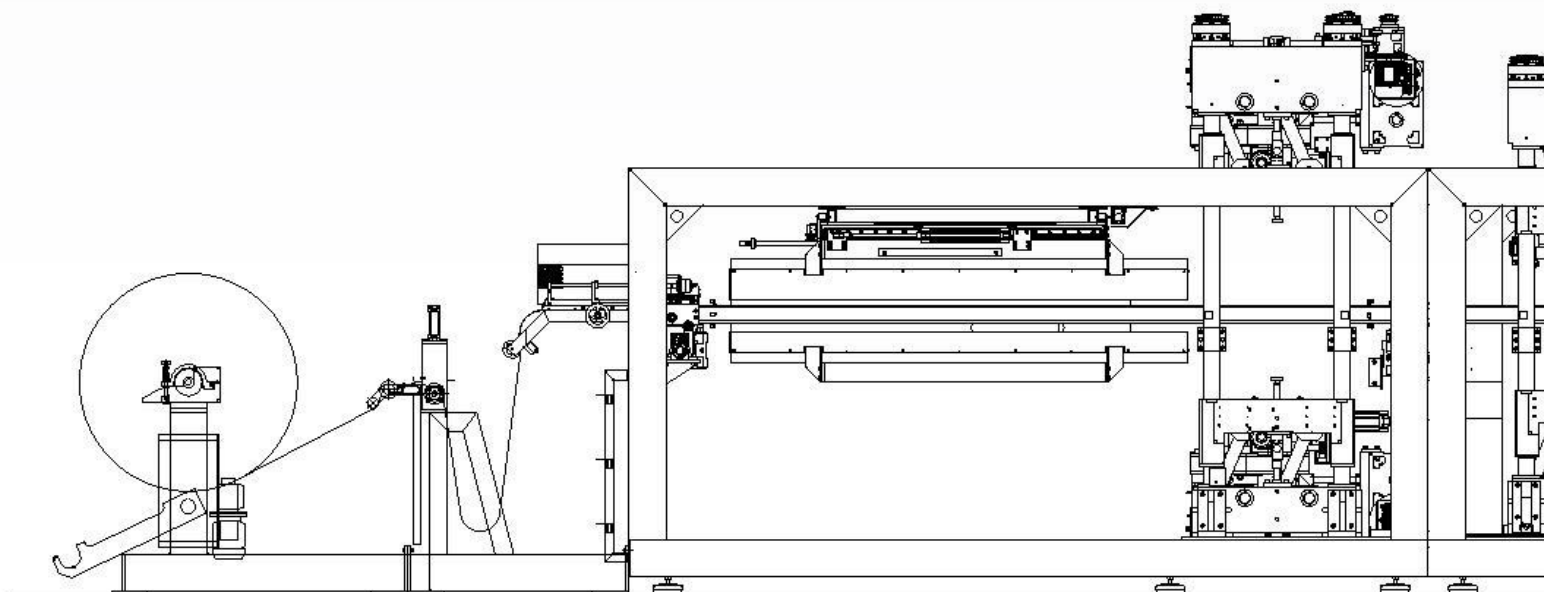

# FORMING THE

## Main features

- Forming 145mm above and below sheet line
- High efficiency heaters
- Increased tonnage in both forming and cutting stations
- In-mould-cut capability
- Optional stacking systems
- Optional punching station
- Multi-purpose thermoformer for food, medical, industrial and other special applications

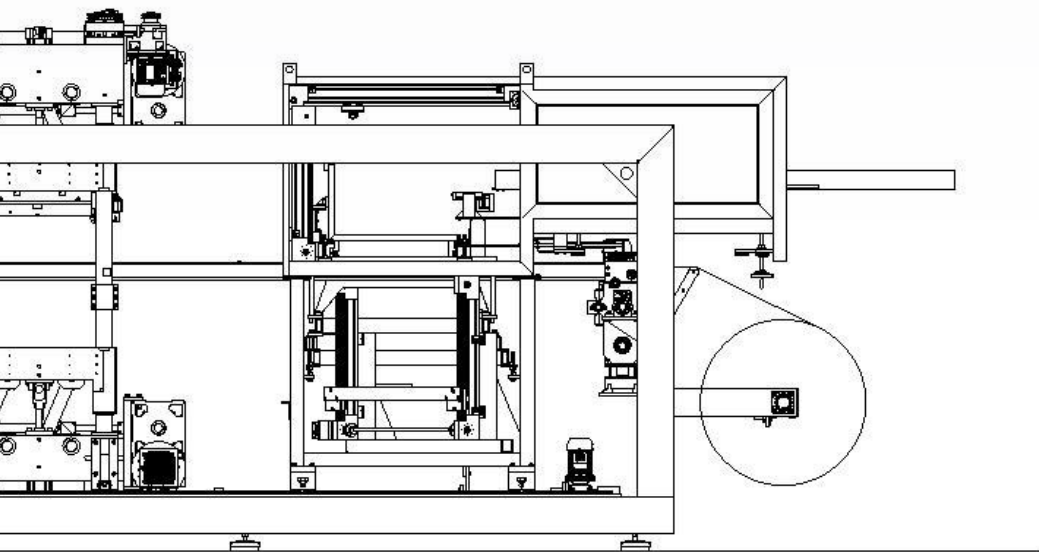

Independent top and bottom servo plug drives for better material distribution

W O R L D

# GN

Thermoforming Equipment



Extra length between forming and cutting stations to allow sufficient cooling when processing PP



Oven is four times the index length of the forming area and incorporates high efficiency heaters







## Specifications

<b>Forming Area</b>	800mm x 570mm (31.5" x 22.4")
<b>Depth of Draw</b> (above and below sheet line)	145mm (5.7")
<b>Clamping Force</b>	75 Ton
<b>Cutting Force</b>	75 Ton
<b>Sheet Width</b> (Maximum)	880mm (34.6")
<b>Sheet Width</b> (Minimum)	450mm (17.7")
<b>Material Thickness</b> (Maximum)	2.0mm (0.80")
<b>Material Thickness</b> (Minimum)	0.25mm (0.010")
<b>Material Roll Diameter</b>	1.2m (47")
<b>Main Supply Voltage</b>	3x400V + N + PE, 50-60Hz (380-415V) 3x480V + PE, 50-60Hz (440-480V)
<b>Running Power Consumption</b>	42 Kilowatts/hr (Approximate)
<b>Air Pressure</b> (Minimum - Maximum)	6.2 bar (90 PSI) - 9.6 bar (140 PSI)
<b>Cycle Speed</b> (Maximum)	45 cpm
<b>Cooling Water Consumption</b> (Maximum)	65 - 200 litres/min (17- 53 gallons/min)
<b>Machine Dimensions</b> (l x w x h)	14529mm x 3886mm x 3200mm (47'8" x 12'9" x 10'6")

SPECIFICATIONS SUBJECT TO CHANGE

*Cost effective tooling designed,  
manufactured and production  
tested at our facility*

# GN

Thermoforming Equipment

**GN's Vision: Build Success With Our Customers!**

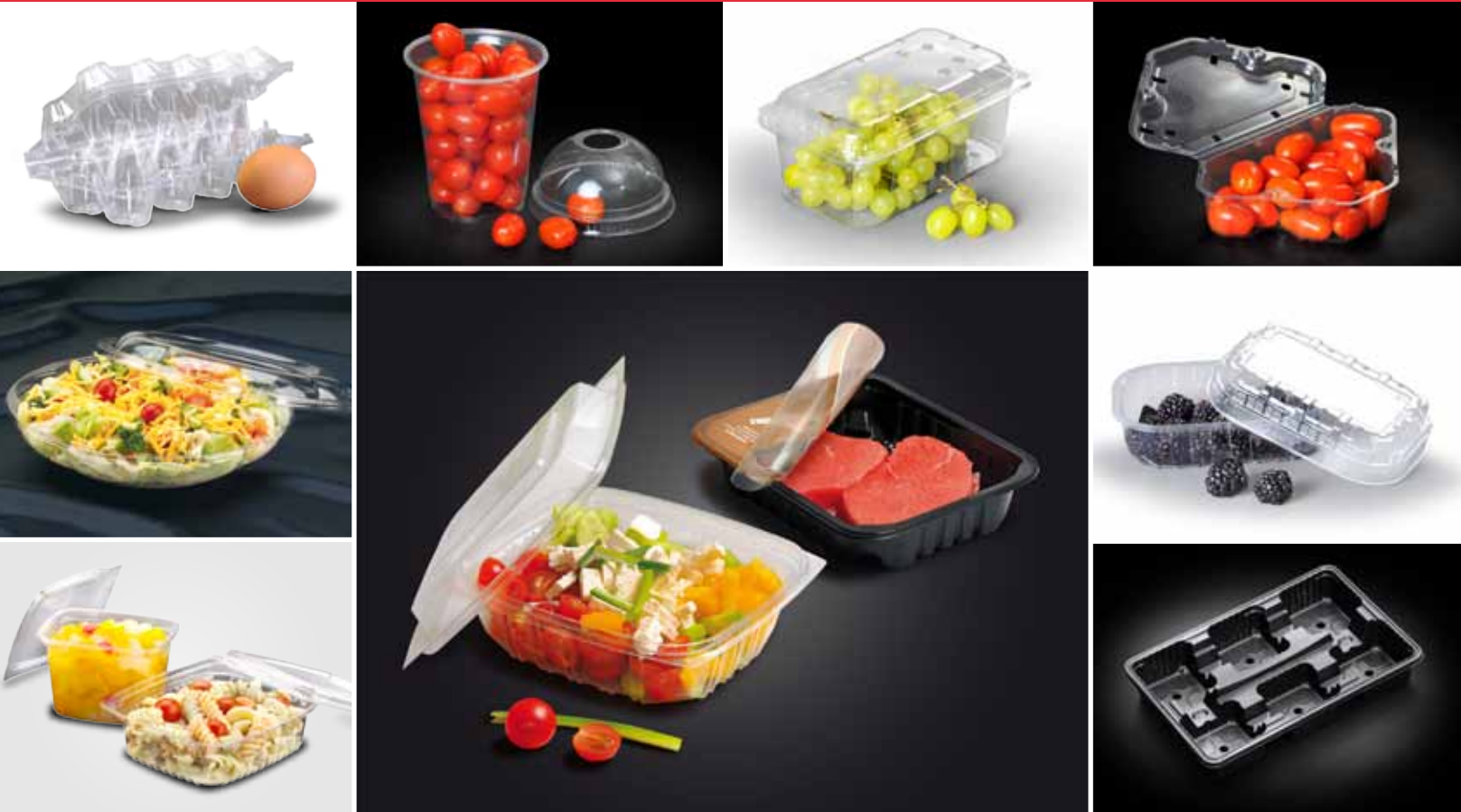

**GN Thermoforming Equipment**  
PO Box 710, 345 Old Trunk 3  
Chester, Nova Scotia  
Canada B0J 1J0  
Tel +1-902/275 3571  
E-Mail [gn@gncanada.com](mailto:gn@gncanada.com)  
[www.gncanada.com](http://www.gncanada.com)

**GN Europe**  
Znojemská 64  
CZ - 586 01  
Jihlava, Czech Republic  
Tel +420 567 313 078  
Fax +420 567 313 079  
E-mail [gn@gneurope.com](mailto:gn@gneurope.com)

A world wide network of GN representatives  
is available to assist you.

ISO 9001-2008



Printed August 2015